

Material List

PART NO.	PART	MATERIAL	AMT
1	HANDLE	1025 STEEL	1
2	ADJ SCREW	1125 STEEL	1
3	CLAMP	CAST STEEL	1
4	BASE	1025 STEEL	1

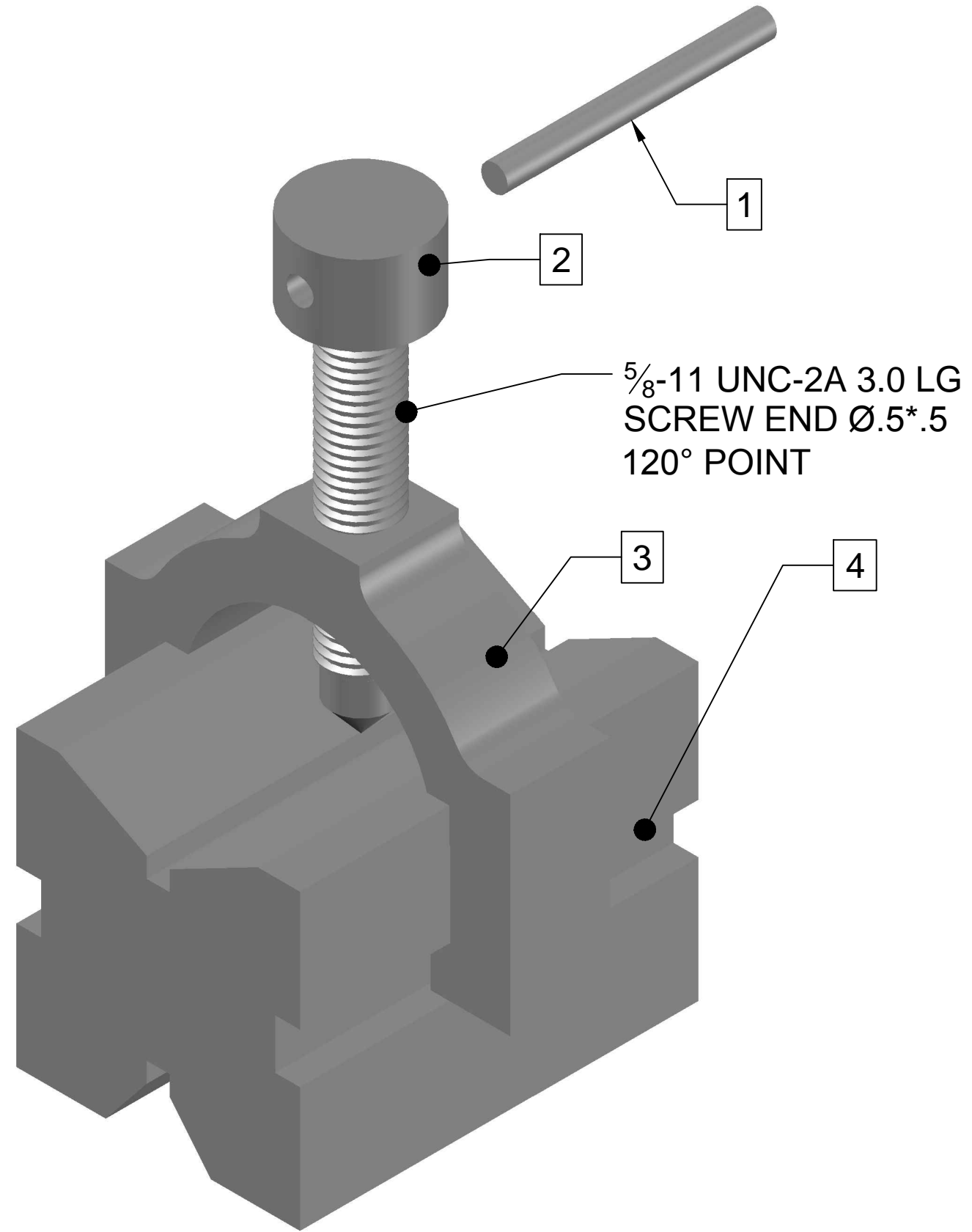

PRODUCED BY AN AUTODESK EDUCATIONAL PRODUCT

PRODUCED BY AN AUTODESK EDUCATIONAL PRODUCT

Digital School

PROJECT:	3D Model of PipeClamp	DRAWN BY: David Tang	COURSE: ECT 310
TITLE:	Asg # 2	CHECKED BY: Dr. Muhib R.	INSTRUCTOR: Dr. Muhib R.
		DATE: 11/12/10	REVISION: .
		SCALE: 1:1	SHEET: 1 OF 1